

10K DUCTILE IRON, GLOBE VALVES

Fig: 610A/10-DGF-N

Sizes: 1/2-2inch(15-50mm)

SCREWED BONNET, INSIDE SCREW, FLAT FACE FLANGED ENDS.

Standards

. End to End: JIS B2002 JV4-2

. End Connection: JIS B2239 10K

. Wall Thickness: JV4-2

Test Standard

. MANUFACTURERS STANDARD

Dimensions

SIZE (inch/mm)	L	L1	H	D1	Kg
1/2 15	85.0	0.0	122.0	70.0	0.00
3/4 20	95.0	0.0	125.0	80.0	0.00
1 25	110.0	0.0	146.0	90.0	0.00
1 1/4 32	130.0	0.0	160.0	100.0	0.00
1 1/2 40	150.0	0.0	180.0	115.0	0.00
2 50	180.0	0.0	198.0	135.0	0.00

Material List

NAME OF PART	MATERIAL	SPECIFICATION
BODY	DUCTILE IRON	FCD-S
BONNET	DUCTILE IRON	FCD-S
STEM	STAINLESS STEEL	SUS420J2
DISC	STAINLESS STEEL	SUS403

Specifications

10K DUCTILE IRON, GLOBE VALVES, SCREWED BONNET, INSIDE SCREW, FLAT FACE FLANGED ENDS.

End to End : JIS B2002 JV4-2, End Connection : JIS B2239 10K, Wall Thickness : JV4-2, Test Standard : MANUFACTURERS STANDARD, Sizes : 1/2-2inch(15-50mm), BODY MATERIAL : DUCTILE IRON, BONNET MATERIAL : DUCTILE IRON, STEM MATERIAL : STAINLESS STEEL, DISC MATERIAL : STAINLESS STEEL, Fig : 610A/10-DGF-N

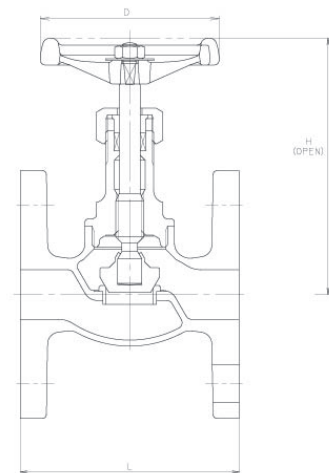

For more details, please refer to the drawing.

Pressure-temperature ratings and other performance data published in this catalog have been developed from our design calculation, in-house testing, field reports provided by our customers and/or published official standards or specifications. They are good only to cover typical applications as a general guideline to users of KITZ products introduced in this catalog. For any specific application, users are kindly requested to contact KITZ Corporation for technical advice, or to carry out their own study and evaluation for proving suitability of these products to such an application. Failure to follow this request could result in property damage and/or personal injury, for which we shall not be liable. Read instruction manual carefully before use.



Toyo Valve

KITZ CORPORATION 1-10-1 Nakase, Mihama-ku, Chiba 261-8577, Japan
© KITZ Corporation. All Right Reserved.

ISO 9001
CERTIFIED
Since 1989